



# *Stainless Steel Table with Removable Top Guide*



## Superior by Design

***Stainless steel tables reimaged and re-engineered from the ground up to eliminate tubular frames and hollow components.***

### Always Stainless

High quality materials result in high quality products for sanitary environments.

### Fully Formed

No tubing or hollow components whatsoever, eliminating areas for bacteria and contaminants to harbor.

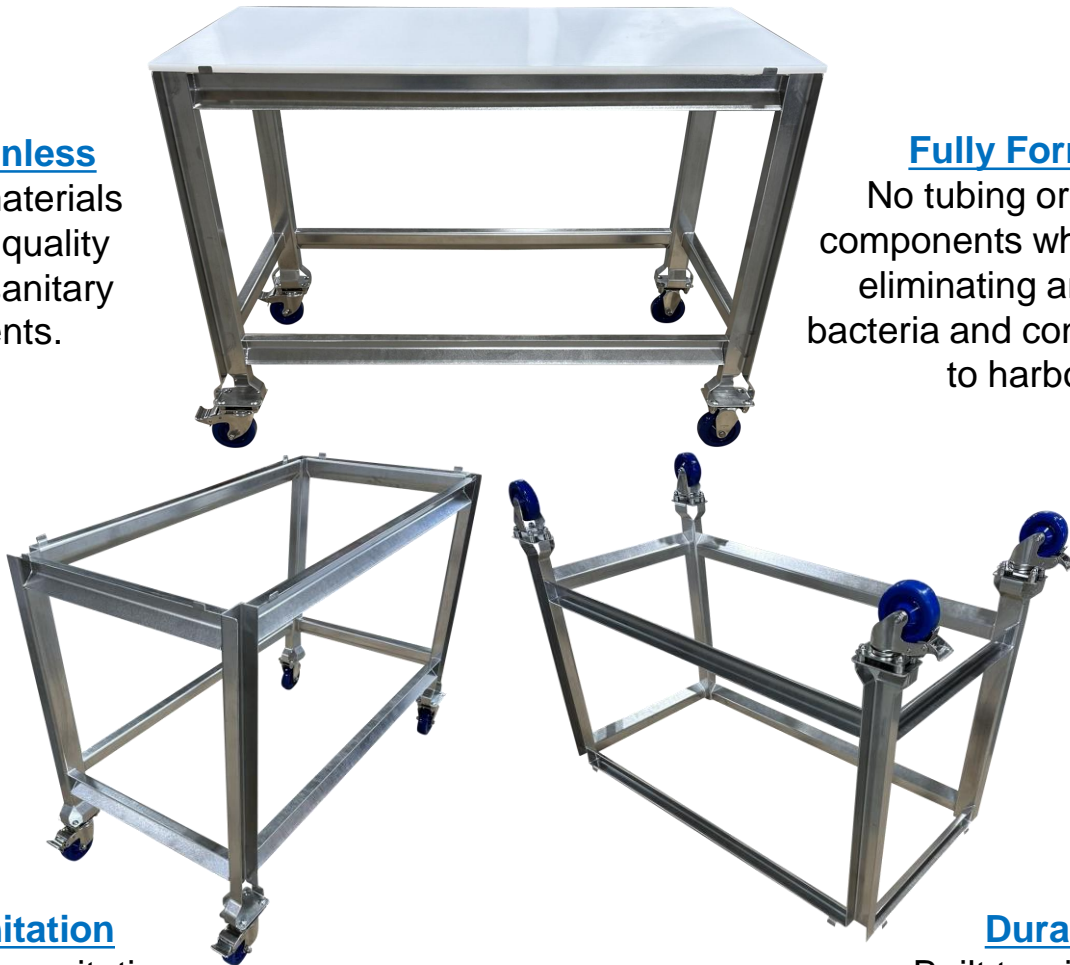

### Simple Sanitation

Engineered with sanitation and maintenance teams in mind. Simple designs mean simple, less time-consuming sanitation.

### Selection

Choose from two different footing options and eight different dimensions to find the table best suited for your needs.

### Durable

Built to withstand prolonged use and harsh routine sanitation.

**SSL Industries, LLC**

Phone: (920) 893-2991

Get a Quote: [sales@sslindustries.com](mailto:sales@sslindustries.com)

[www.sslindustries.com](http://www.sslindustries.com)



### Top

Formed tabs around the perimeter of the top of the frame allows for the customer to place desired removable working surface. Our patented design eliminates all closed channels and requires no nuts, bolts, or threads for assembly.

### Frame

The frame is constructed of 11 gauge / 304 stainless steel and utilizes completely formed components (no tubular or hollow components). The frame is TIG welded complete and the table is fully assembled.

### Finish

All components receive a dual-action medium Scotch-Brite finish and all welds are passivated.

### Footing Options

- Paw Print
- Casters

### Shipping

All tables ship LTL/FTL

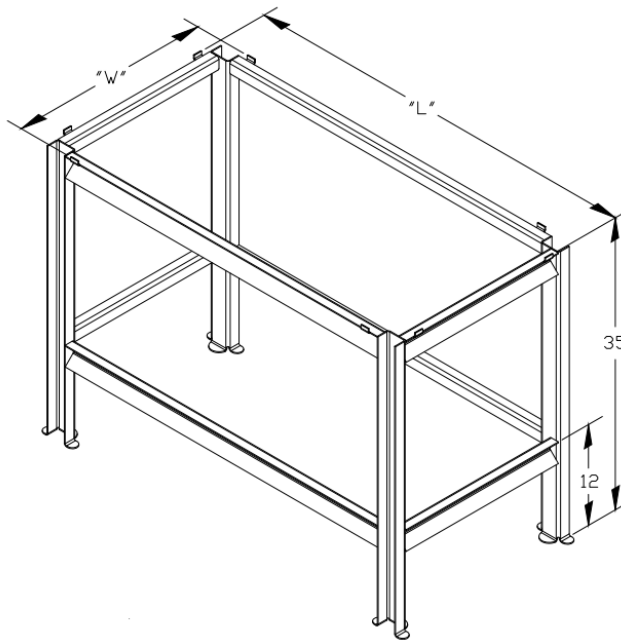

### Standard Dimensions

Length	Width	Height
36"	24"	35"
36"	30"	35"
48"	24"	35"
48"	30"	35"
60"	24"	35"
60"	30"	35"
72"	24"	35"
72"	30"	35"

**SSL Industries, LLC**

Phone: (920) 893-2991

Get a Quote: [sales@sslindustries.com](mailto:sales@sslindustries.com)

[www.sslindustries.com](http://www.sslindustries.com)



**Industries**  
CLEAN SAFE SIMPLE®

**Stainless Steel Table with  
Removable Top & Paw Print Footing**  
Model Series SSL-1002



- SSL Industries' proprietary design
- (3) Formed tabs on the base of the foot for ample stability
- Most preferred option by regulatory bodies due to inherit clean design and sanitation
- USDA Accepted Equipment
- Per the USDA, compliant with the NSF/ANSI/3-A SSI-14159-1-2019 Hygiene Requirement for the Design of Meat and Poultry Processing Equipment

Model No.	Dimensions			Footing	Price / Ea. @ Qty:		
	L	W	H		1	5	10
SSL-1002-36X24	36"	24"	35"	Paw Print	\$640	\$615	\$595
SSL-1002-36X30	36"	30"	35"	Paw Print	\$665	\$645	\$620
SSL-1002-48X24	48"	24"	35"	Paw Print	\$720	\$695	\$670
SSL-1002-48X30	48"	30"	35"	Paw Print	\$750	\$725	\$695
SSL-1002-60X24	60"	24"	35"	Paw Print	\$860	\$830	\$800
SSL-1002-60X30	60"	30"	35"	Paw Print	\$905	\$875	\$845
SSL-1002-72X24	72"	24"	35"	Paw Print	\$945	\$910	\$880
SSL-1002-72X30	72"	30"	35"	Paw Print	\$990	\$955	\$920

**Prices do not include removable top**

**SSL Industries, LLC**

Phone: (920) 893-2991

Get a Quote: [sales@sslindustries.com](mailto:sales@sslindustries.com)

[www.sslindustries.com](http://www.sslindustries.com)



- Standard 4" solid blue polyurethane wheels
- (2) Rigid and (2) swivel with total locking brakes
- Load capacity of 300 lbs. per caster (1,200 lbs. per table)
- Temperature resistance -40°F to +180°F
- ½" Stainless steel spacers between footing and caster plates
- Stainless steel carriage bolts and acorn nuts
- USDA Accepted Equipment
- Per the USDA, compliant with the NSF/ANSI/3-A SSI-14159-1-2019 Hygiene Requirement for the Design of Meat and Poultry Processing Equipment

Model No.	Dimensions			Footing	Price / Ea. @ Qty:		
	L	W	H		1	5	10
SSL-1002-C-36X24	36"	24"	35"	½" SS Spacers & 4" Casters	\$1,115	\$1,075	\$1,035
SSL-1002-C-36X30	36"	30"	35"	½" SS Spacers & 4" Casters	\$1,140	\$1,100	\$1,065
SSL-1002-C-48X24	48"	24"	35"	½" SS Spacers & 4" Casters	\$1,195	\$1,155	\$1,115
SSL-1002-C-48X30	48"	30"	35"	½" SS Spacers & 4" Casters	\$1,225	\$1,180	\$1,140
SSL-1002-C-60X24	60"	24"	35"	½" SS Spacers & 4" Casters	\$1,335	\$1,290	\$1,245
SSL-1002-C-60X30	60"	30"	35"	½" SS Spacers & 4" Casters	\$1,380	\$1,335	\$1,285
SSL-1002-C-72X24	72"	24"	35"	½" SS Spacers & 4" Casters	\$1,420	\$1,370	\$1,320
SSL-1002-C-72X30	72"	30"	35"	½" SS Spacers & 4" Casters	\$1,465	\$1,415	\$1,365

**Prices do not include removable top**